

Welcome
@
PLCopen Motion Control
-
changing the world
of industrial automation

Eelco van der Wal
Managing Director PLCopen



IEC 61131-3



**Harmonizing the way people look to
control**

and PLCopen extends this basis

PLCopen Motion Control :



**The merge of
Logic and Motion**

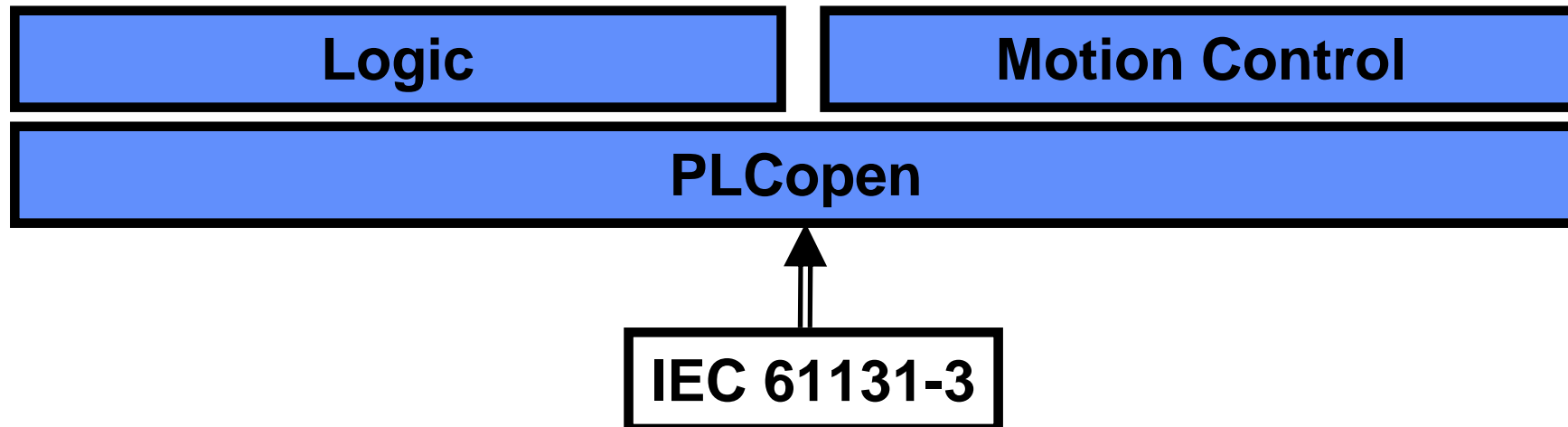
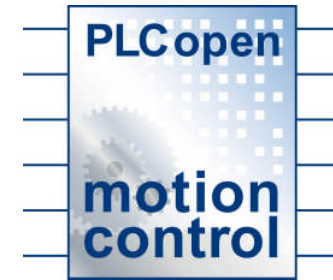

The next step: Adding Safety (at machine level)

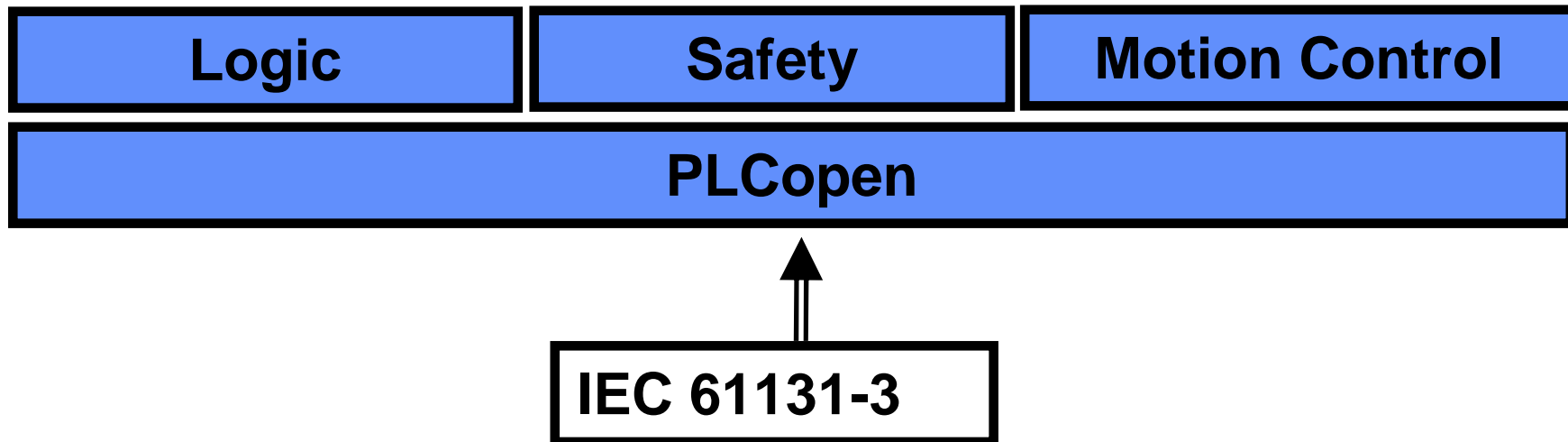

PLCopen

Combining Logic, Motion and Safety

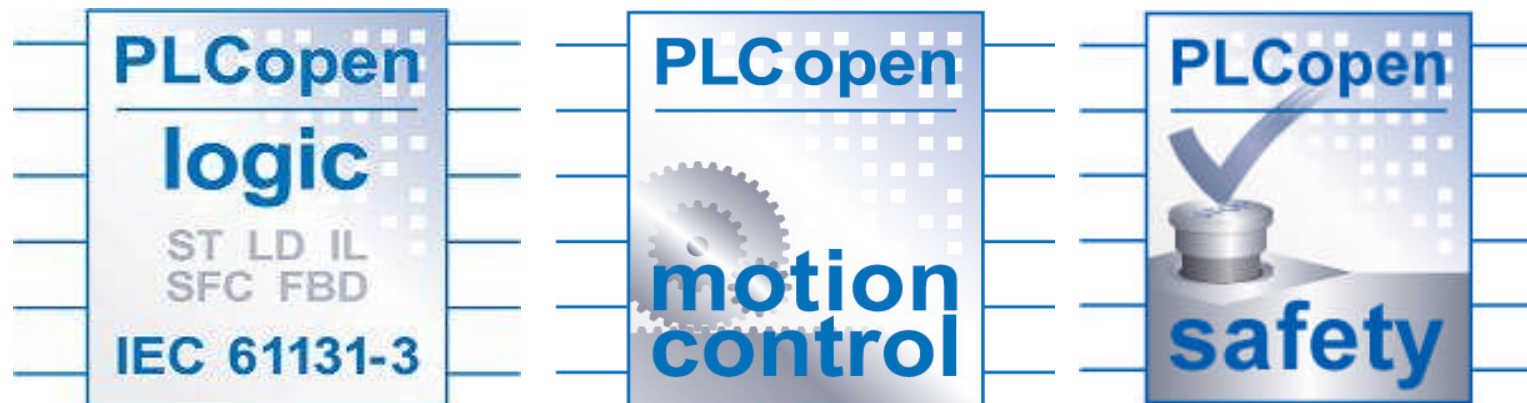

**Providing Structuring, Decomposition,
Reuse and less training**

Percentage of Software development costs in production systems (source: McKinsey)

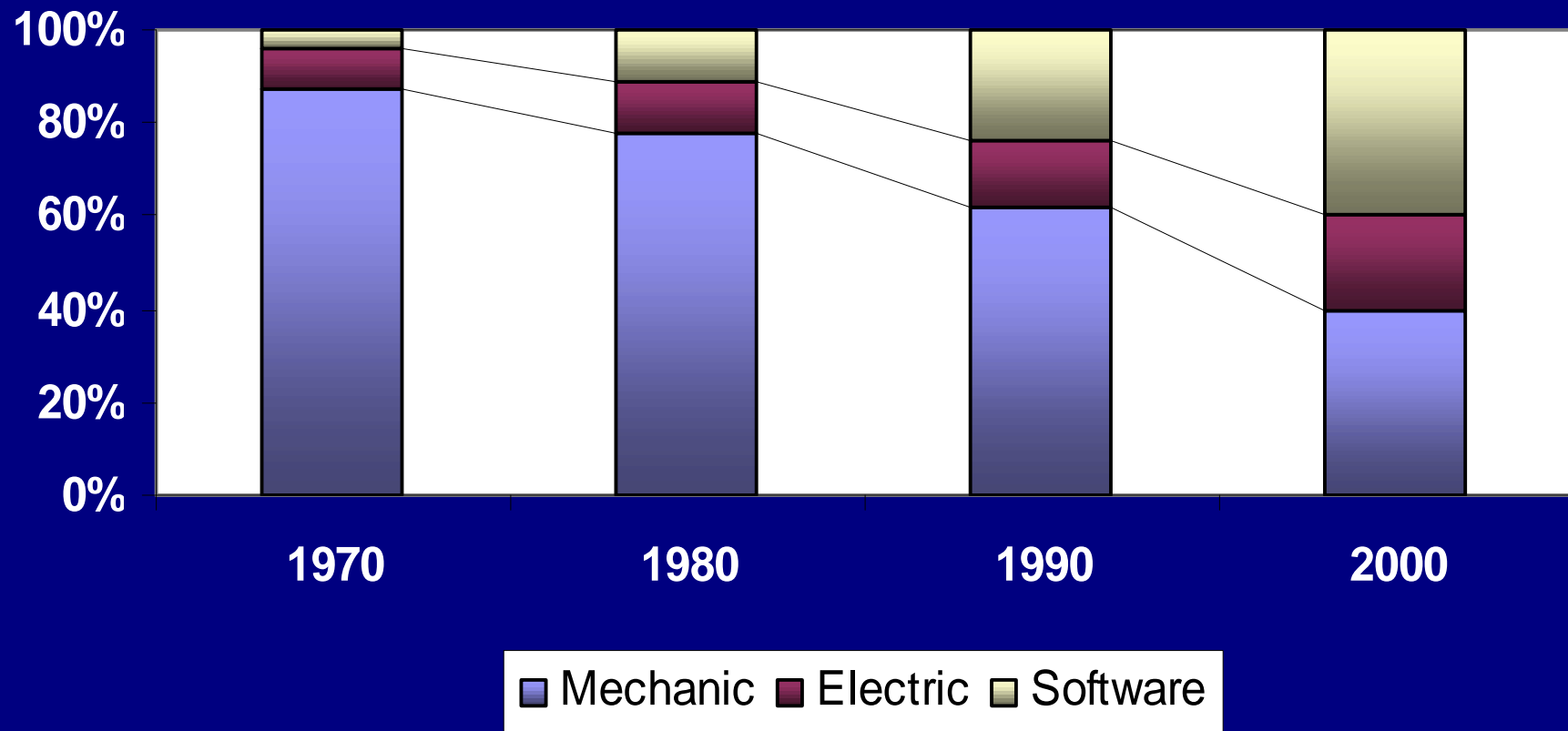

Managing Complexity

100 – 10,000 – 1mio – 100mio Lines of Code

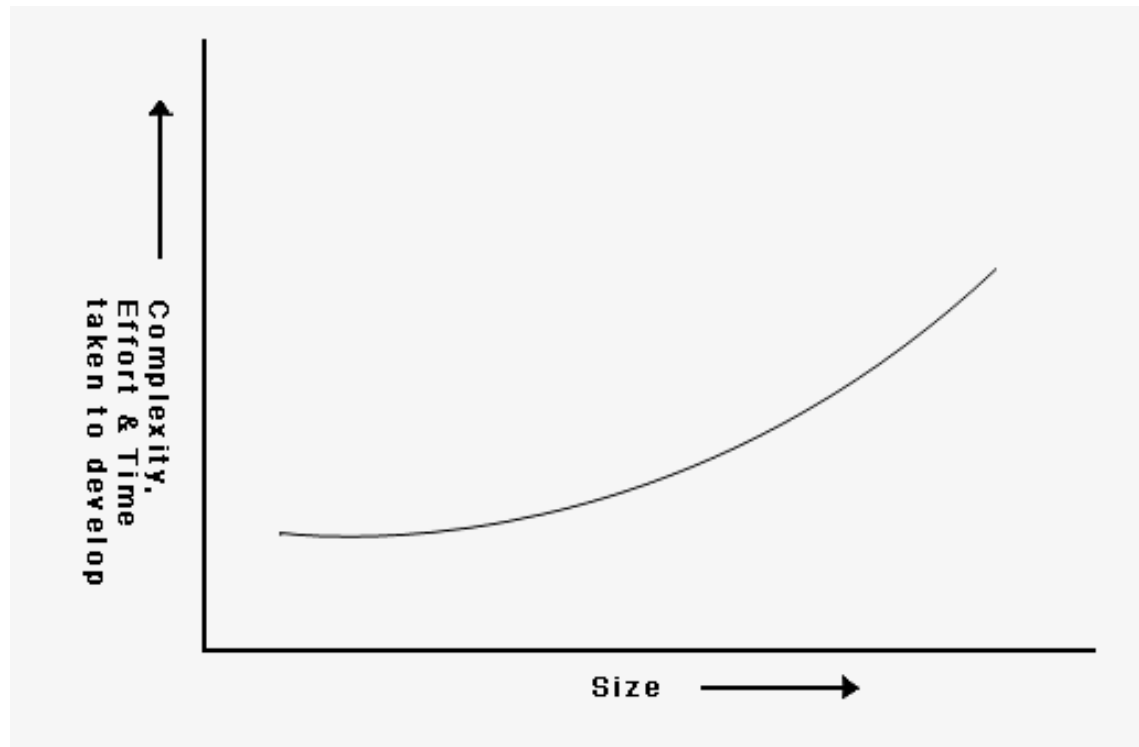

A hierarchy of abstraction

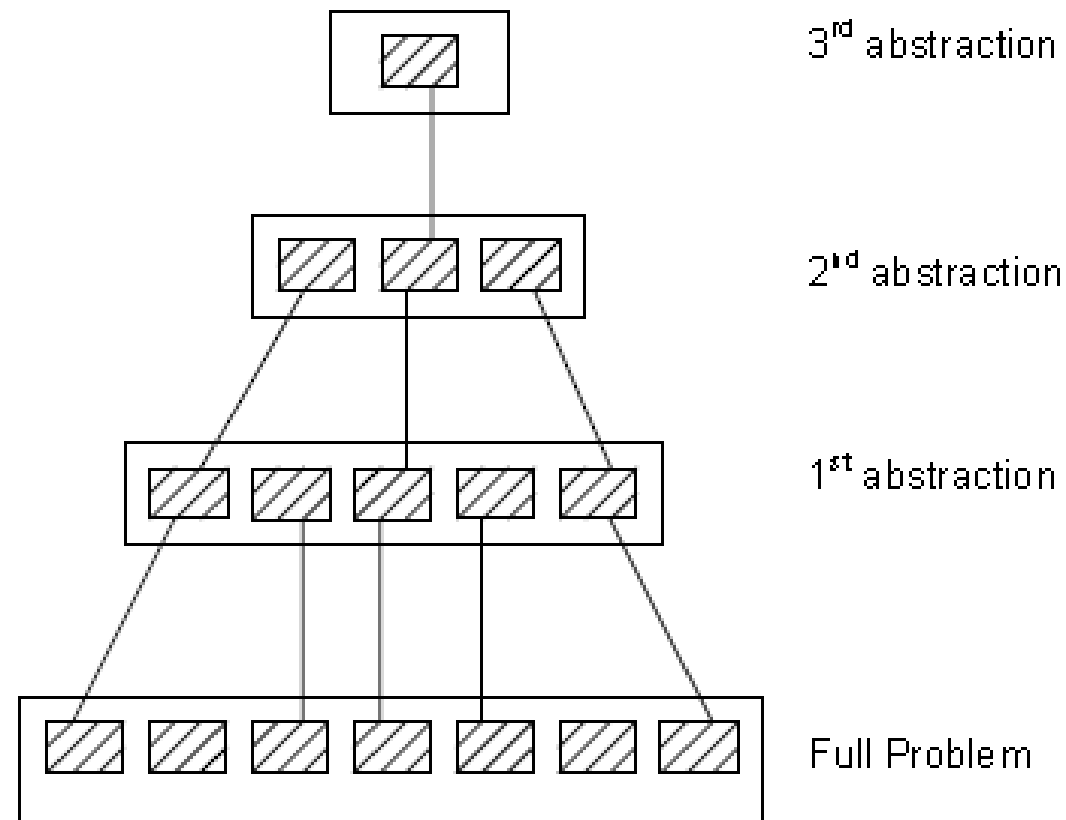

Decomposition and Reuse

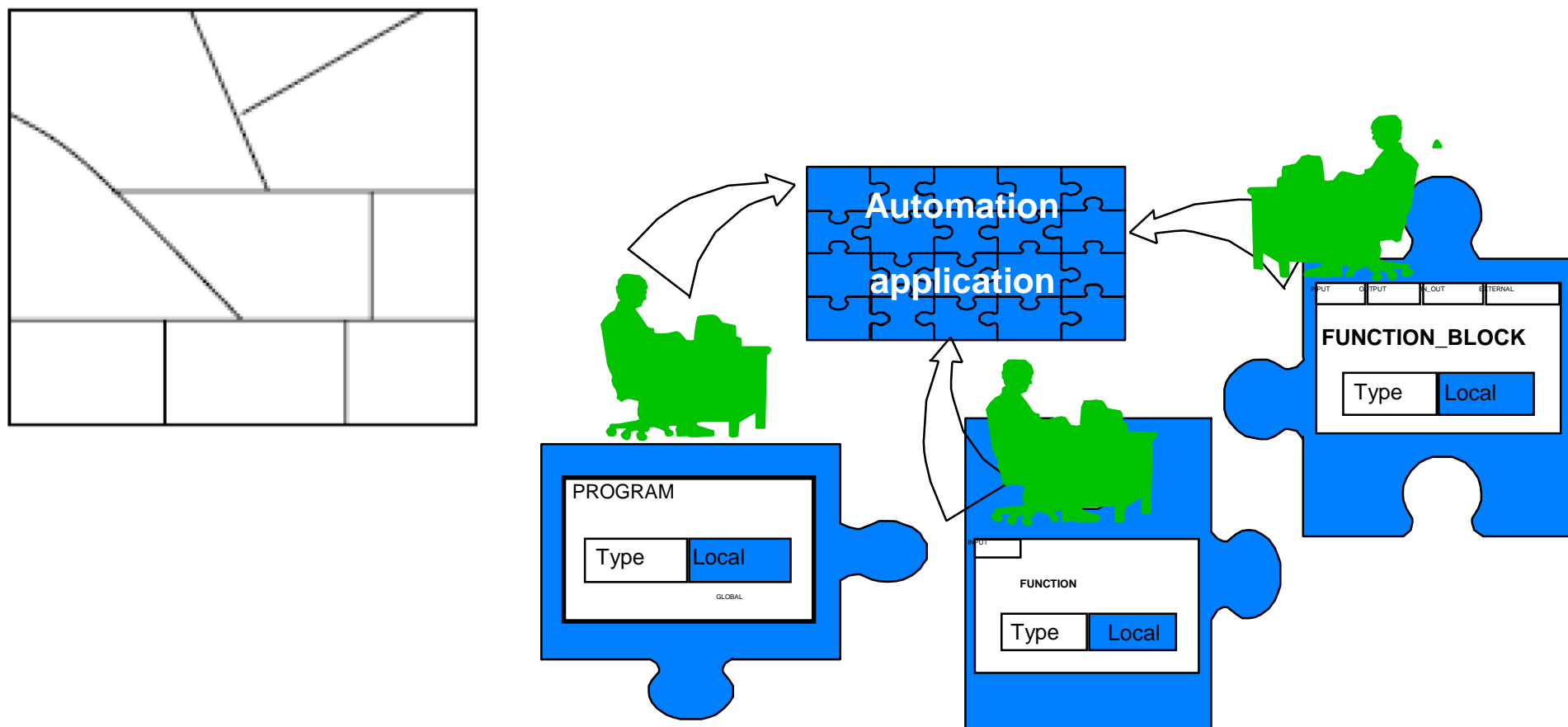

Abstraction via Function Blocks

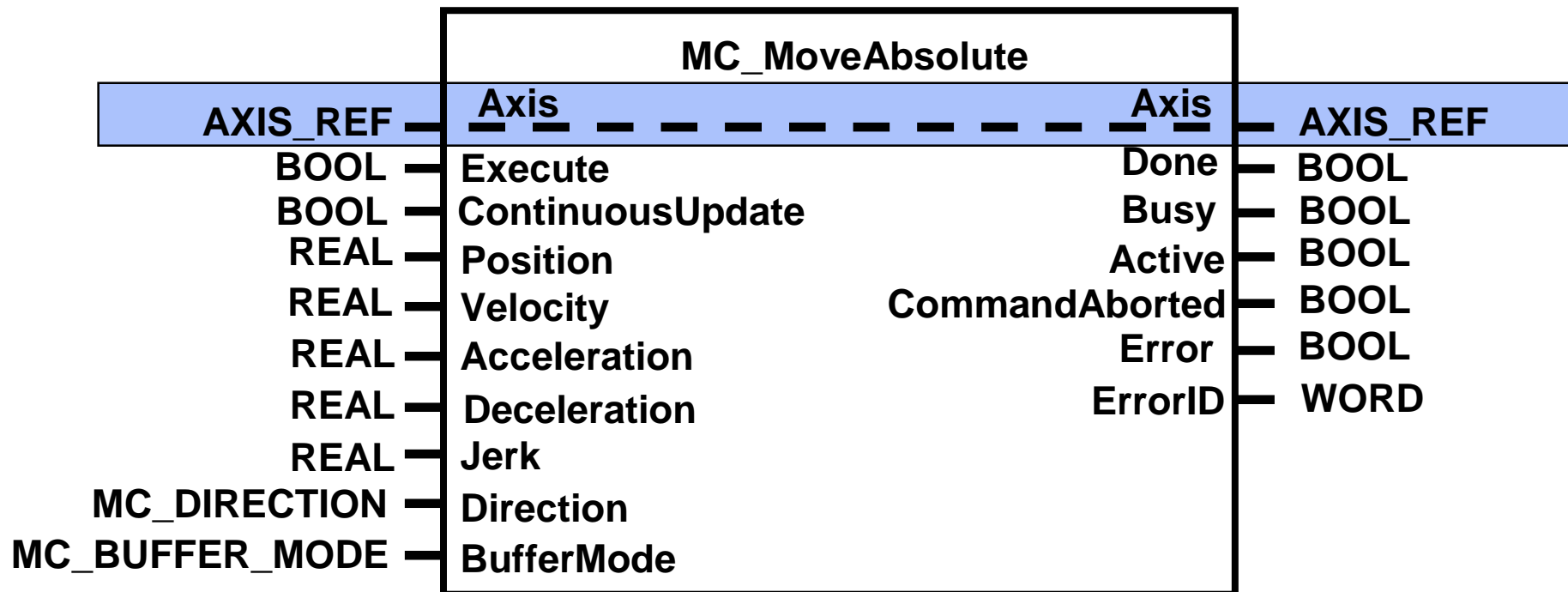

Axis_Ref with 1 FB

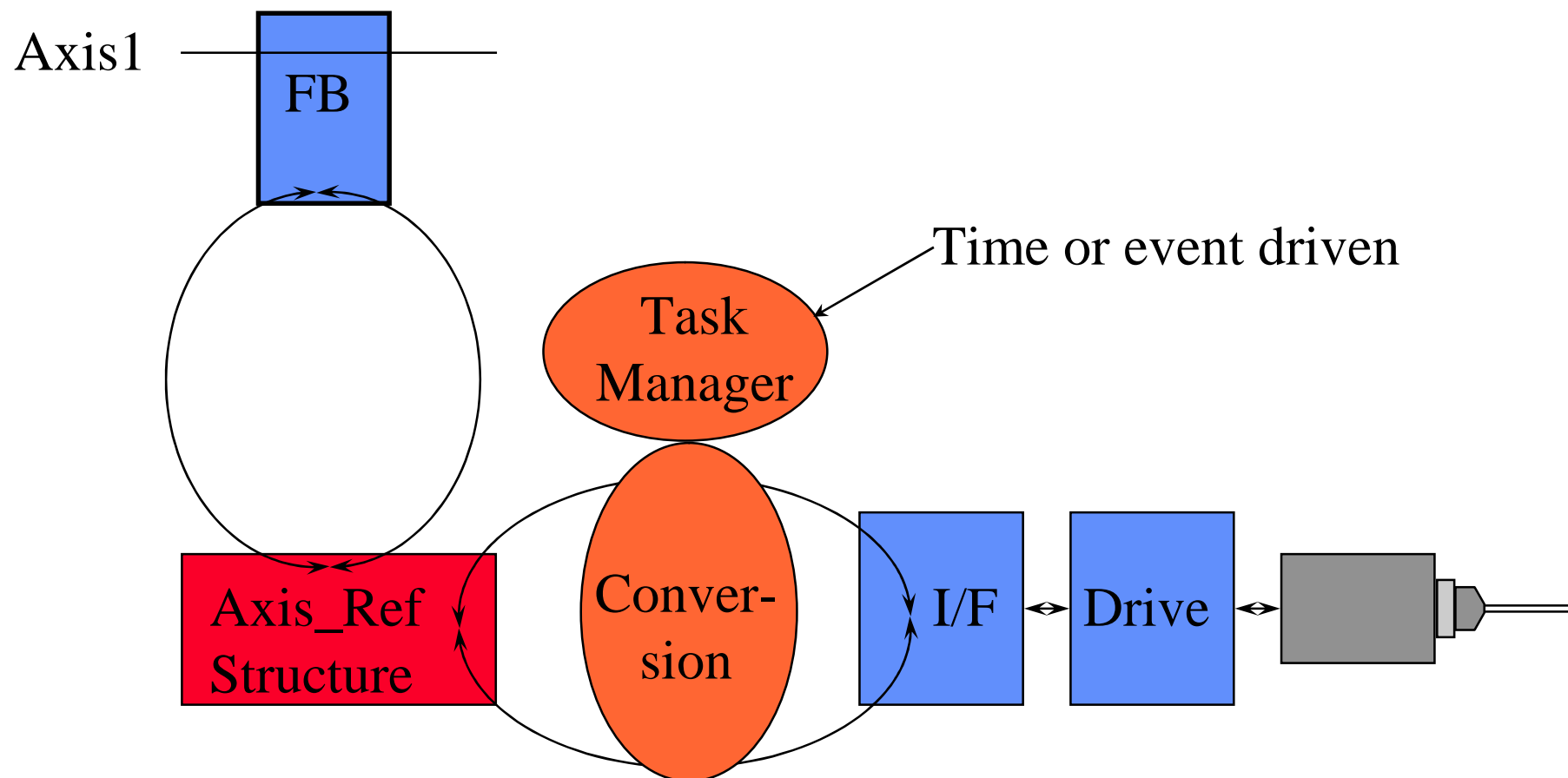

Axis_Ref with 2 FBs

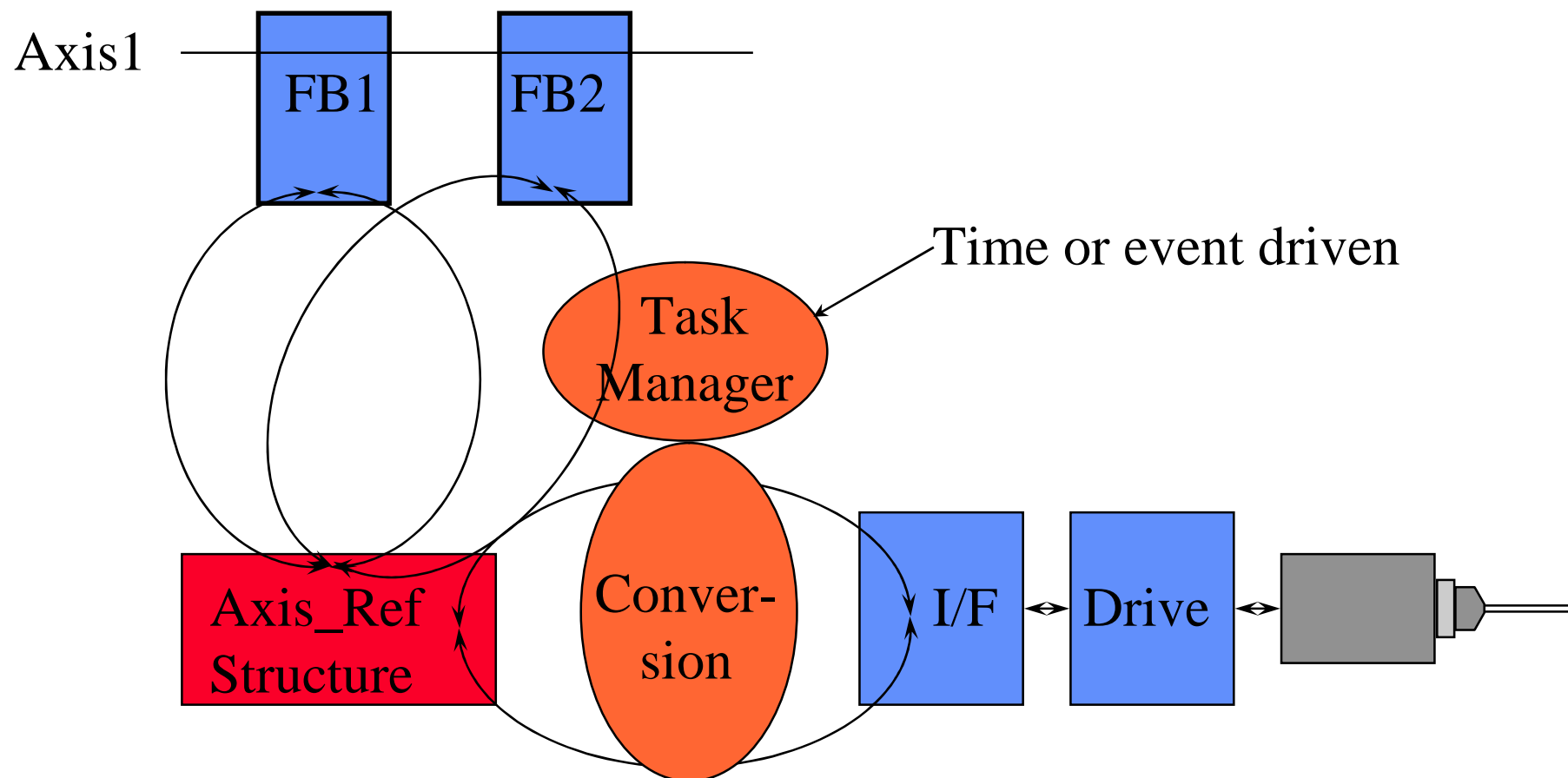

Encapsulation: Webcutting

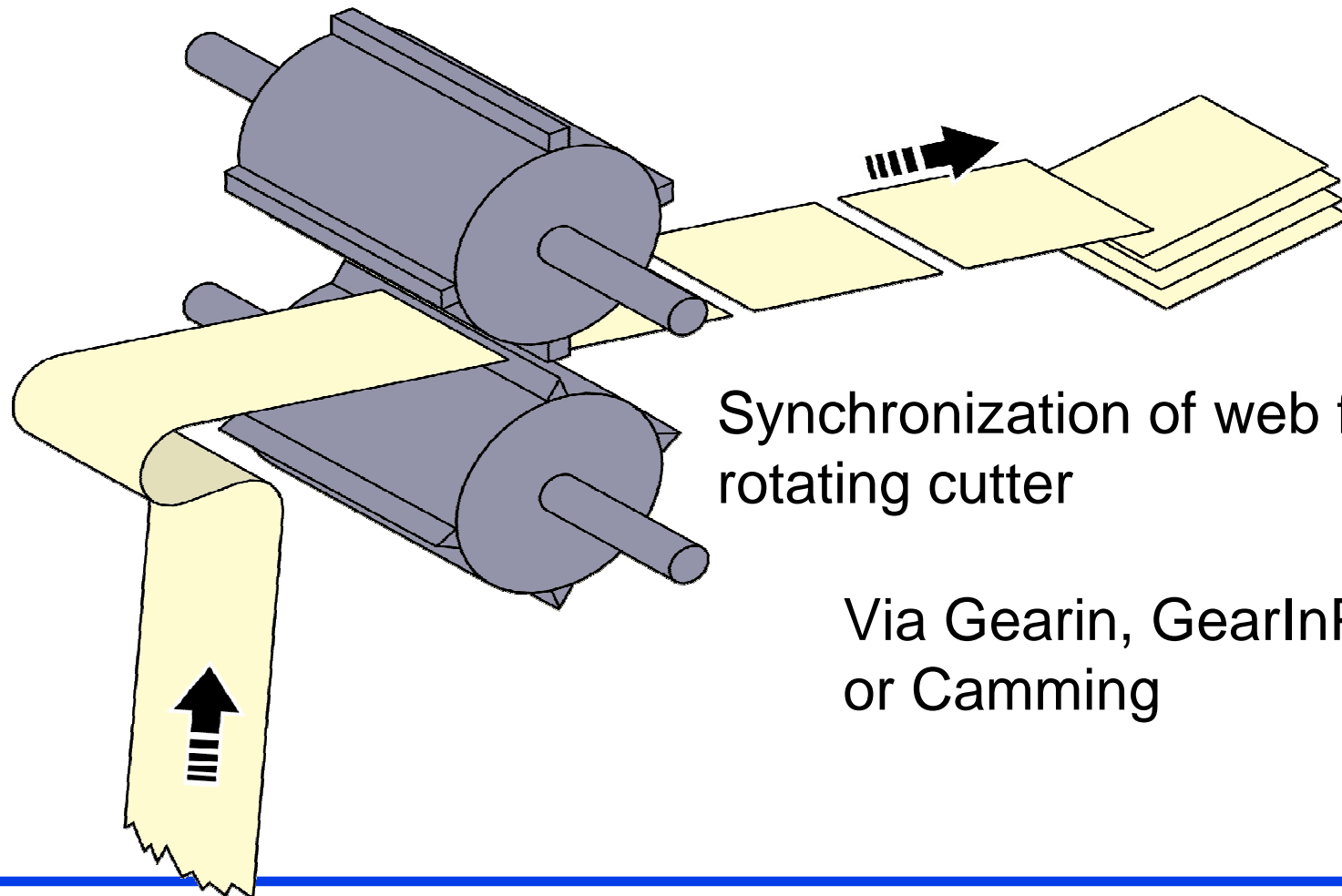

Synchronization of web feeding & rotating cutter

Via Gearin, GearInPosition
or Camming

Mechatronic solutions

**Mechanical
solution**

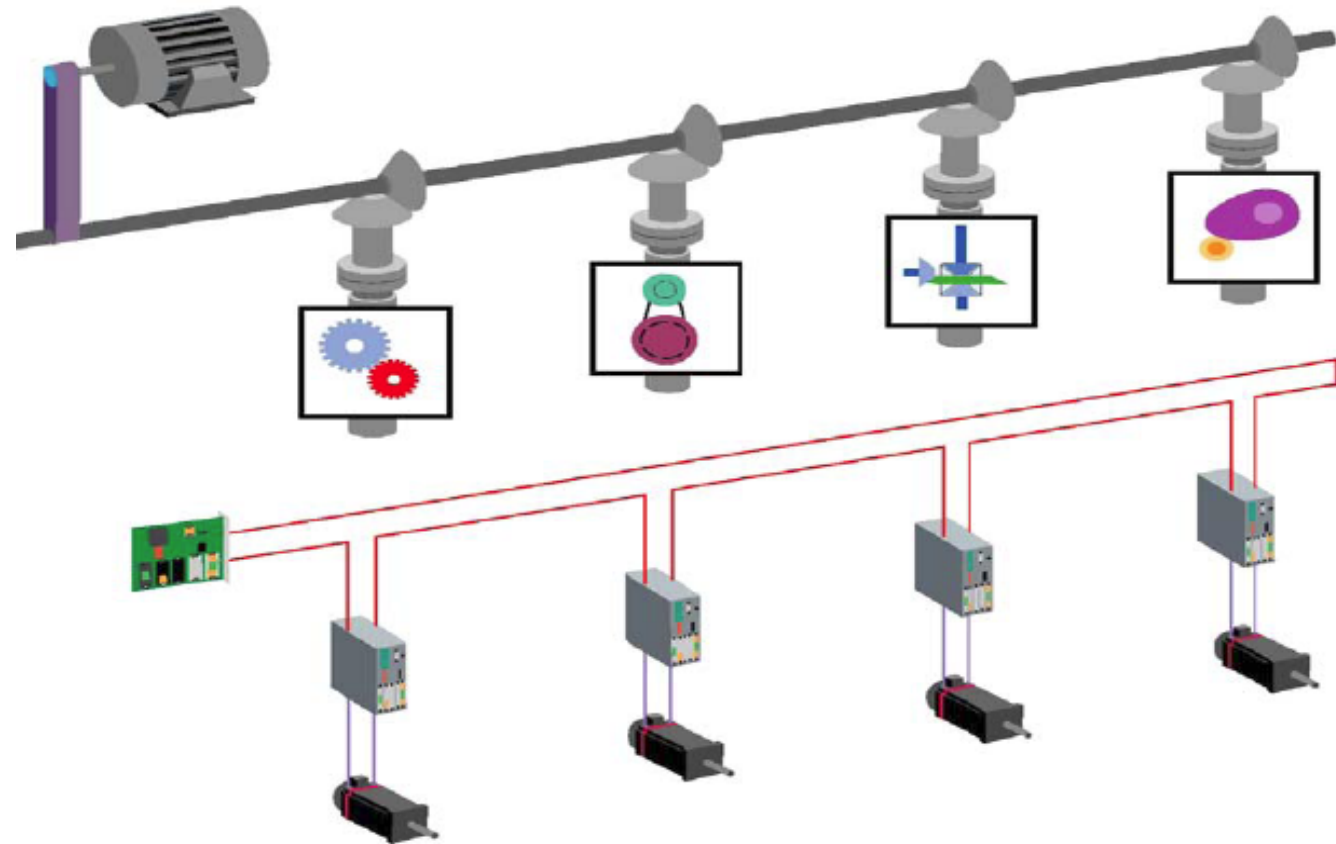

**Control
solution**

Time-to-Market

via flexibility in equipment and process

Asset utilization

minimal finished good inventory

Flexibility in Manufacturing

process followed by packaging to provide end product

Overall Equipment Efficiency OEE



The integration of Part 1 and Part 2

Status PLCopen Motion Control

- **Part 1 – FBs, V. 1.0 - 2001, V. 1.1 - 2005**
- **Part 2 – Extensions (2005)**
- **Merge of Part 1 and 2 - MC version 2.0 (2011)**
- **Part 3 – User Guidelines (2008)**
- **Part 4 – Coordinated Motion (2008)**
- **Part 5 – Homing procedures (planned 2011)**
- **Part 6 – Fluid Power (planned 2011)**



Planned PLCopen Motion Control Releases

- **Update of Part 3 – User Guidelines**
- **Release of Part 5 – Homing**
- **Release of Part 6 – Extension for Fluid Power**

Status PLCopen Motion Control

- **25 companies certified with 37 products**
- **check website for overview and full list**



PLCopen Motion Control 2.0

- **Consistent naming conventions and definitions**
 - **Input 'Continuous Update'**
 - **New FB CombineAxes,**
 - **Representation of the State Diagram**
 - **New input MasterValueSource**
 - **New FBs ReadMotionState and ReadAxisInfo**
 - **Split of Phasing and MoveContinuous FBs in to both relative and absolute versions**
 - **Clearer specified behavior of the output Active**
-

Input Continuous Update: Winding / Unwinding

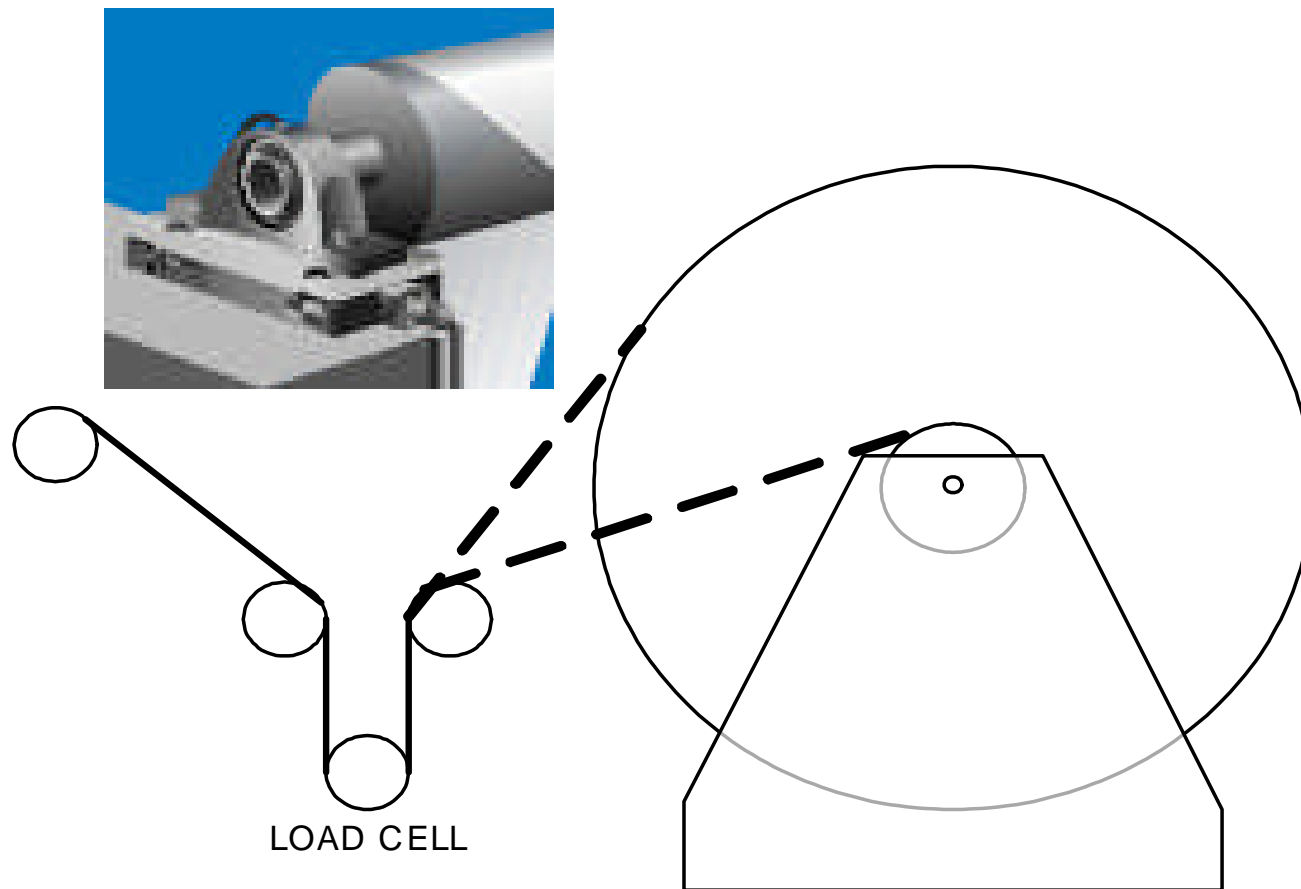

2-cycle approach with Execute

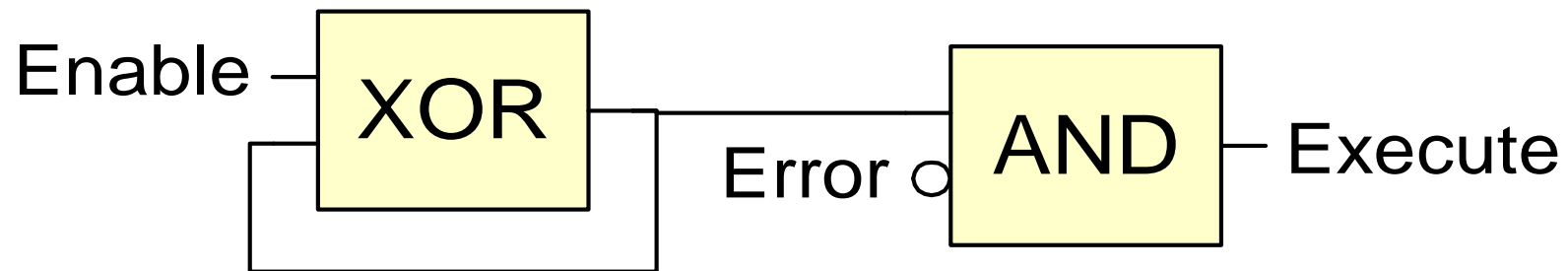

In1	In2	Out
T	F	T
T	T	F
T	F	T

Input Continuous Update

- **With Continuous Update set, the inputs are used every cycle**
- **With Continuous Update not connected or not set – no change in behavior**
- **Benefits in fast scaling movements and in dynamic behavior**

Combine Axes

- **A new Function Block CombineAxes, combining the motion of 2 axes into a 3rd axis with selectable combination method. Basically it is a calculation of a new position setpoint based on the 2 position setpoints of the input axes.**

Example Combine Axes

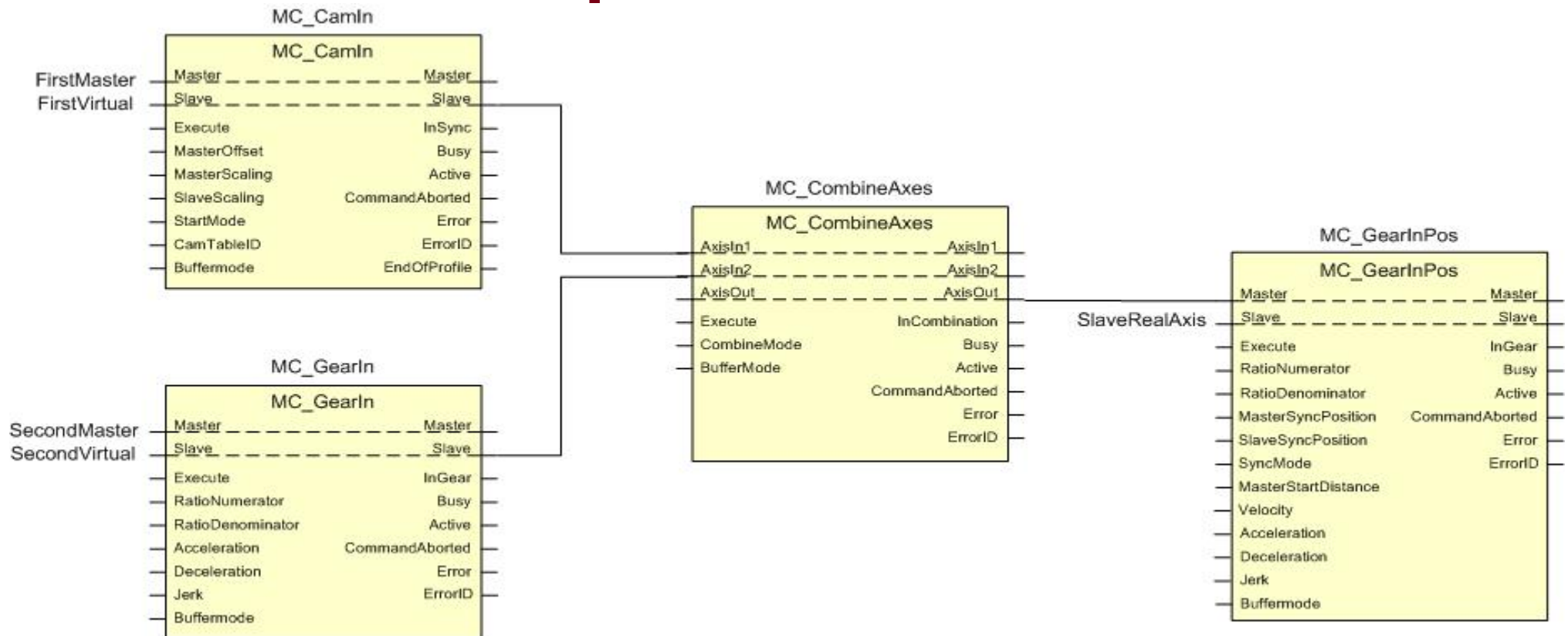

Representation State Diagram PLCopen *for efficiency in automation*

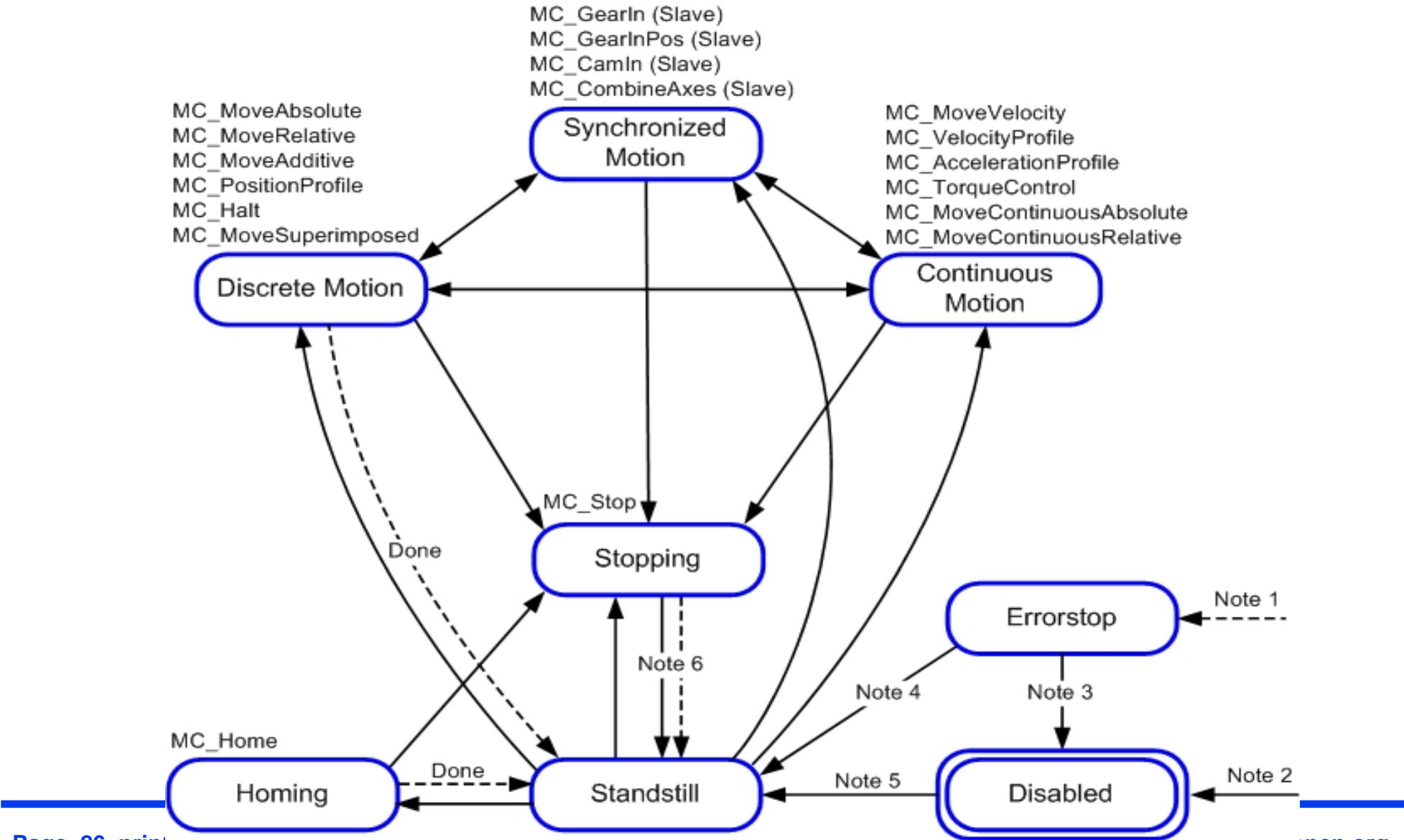

Input MasterValueSource

- **Defines the source for synchronization:**
 - mcSetValue - Synchronization on master set value
 - mcActualValue - Synchronization on master actual value

- **Relevant for MC_CamIn, MC_GearIn, MC_GearInPos, MC_ReadMotionState, and MC_CombineAxes**

**More Information...
and to download the specifications**

www.plcopen.org

email: evdwal@plcopen.org

Thanks

